

SUNERGY USA WORKS LLC
INSTALLATION INSTRUCTION MANUAL
CRYSTALLINE PV MODULE

1. INTROUDUCTION

SUNERGY USA WORKS LLC is a hi-tech company engaged in the development, research , production, sales and service of solar panels, and photovltaic systems.

1.1 POWER MODULE

Sunergy Solar Photovltaic modules consist of a series of electrically interconnected cyrstalline silicon solar cells. Which are permanently encapsulated between a tempered glass superstrate and substrate. The entire laminate is secured within an anodized aluminum frame for structural strength; ease of installation and to protect the cells from the most severe enviromental conditions.

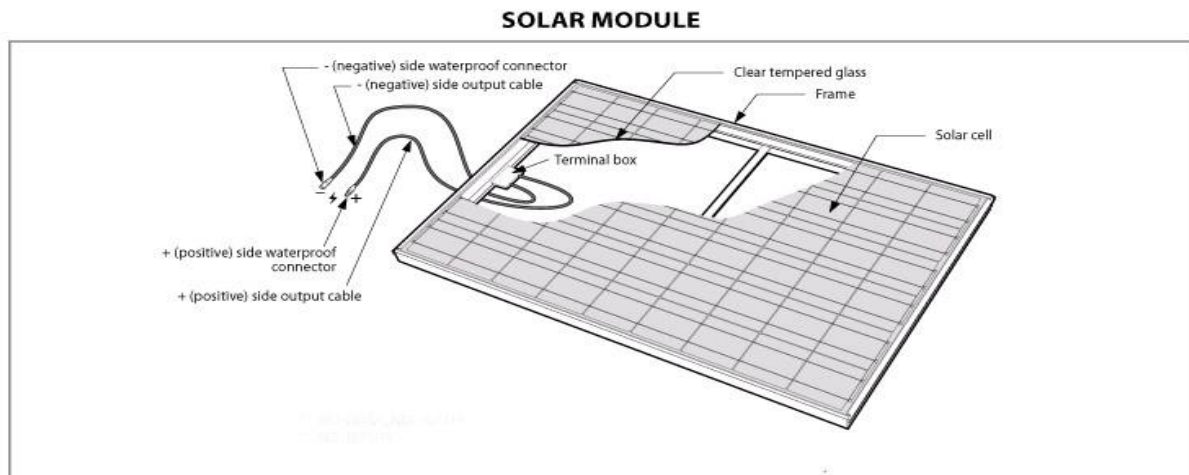

2. APPLICATIONS

Sunergy PV modules are a highly reliable, virtually maintenance-free direct current (DC) power source, designed to operate most efficiently in sunlight. Sunergy series modules are ideal to power remote homes, recreational vehicles, water pumps, telecommunications sytems and many other applications either with or without the use of storage batteries. Class A, Modules rated for use in this application class may be used in systems operating at greater than 50V DC or 240W, where general contact access is anticipated. Modules qualified for safety through this part of IEC 61730 and IEC 61730-2 and within this application class are considered to meet the requirements for safety class II.

Notes: The recommended maximum series/parallel module configurations are as follow:

- 72 6 "mono series
- 60 6 " mono series
- 72 6 " poly series
- 60 6 " poly series

3. PERMIT

Before installing yours system, contact local authorities to determine the necessary permit, installation and inspection requirements.

4. CLIMATE CONDITION

Install the Sunergy Solar crystalline series modules in the following conditions:

Ambient temperature: -20°C to + 40°C

Operating temperature: -40°C to +85°C

Storage temperature: -40°C to +40°C

Humidity: below 85RH%

Wind pressure: below 50.12lb / ft² (2400Pa)

Corrosion resistance: Except for corrosive salt area and sulfurous area.

5. WARNING AND NOTES FOR SAFE INSTALLATION WORK

This system shall be installed only by engineers who have completed the training course.

Each solar panel has a junction box, can provide cable according to customer's requirement.

Installers must know the possible danger of death or serious bodily injury.

Do not cut the connection wire under the loading .

Do not modify solar panel, move any labels or other parts.

Do not use chemicals on solar panel surfaces.

Do not expose solar panels to sunlight that is concentrated with mirrors, lenses or similar means.

Solar panel installation must obey the local law, even it should get the Construction Licence.

Do not wear the things, such as rings, metal jewelry, diamond jewelry or tools. which can damage the surface of module during the installation process.

6. SAFETY REGULATIONS REGARDING INSTALLATION OF SOLAR POWER SYSTEMS

6.1 Take the following precautions before starting work

Plan the job and visit the site before starting work. On site, do not work alone. Always work with at least one other person. Inspect power tools before using them

6.2 Observe safety regulations during installation

Do not wear metallic jewelry, which may cause electrical shock

Keep the back side of solar panel surfaces free of foreign objects

Completely cover solar panel with opaque materials when wiring to halt productions of electricity.

7. REQUIRED INFORMATION

Artificially concentrated sunlight shall not be directed on the panel.

"Rated electrical characteristics are within 10 percent of measured values at Standard Test Conditions of : 1000 W/M², 25°C cell temperature and solar spectral irradiance per ASTM E 892 or irradiation of AM 1.5 spectrum.

Under normal conditions, a photovoltaic panel may experience conditions that produce more current and/or voltage than reported at Standard Test Conditions. Accordingly, the values of ISC and VOC marked on should be multiplied by a factor of 1.25 when determining component voltage ratings, conductor capacities, fuse sizes and size of controls connected to the panel output. Refer to Section 690-8 of the National Electric Code for an additional multiplying factor of 1.25 which maybe applicable.

8. POINTS TO CHECK WHEN SELECTING THE INSTALLATION LOCATION

- 8.1 The direction toward the equator to install solar modules, if possible. Installations facing east and west are also possible, although the amount of power generated will be lower.
- 8.2 Install in a location that has good sun exposure throughout the year. Less power is generated in shaded locations.
- 8.3 The output of a series string of solar panels is connected to the input of the inverter. Always install solar panels so that all elements of the array receive the same amount of sunlight.
- 8.4 It may not be possible to install solar panels in regions where maximum snow accumulation exceeds the maximum allowable load.

9. MOUNTING AND NOTES

The module frame is made of anodized aluminum, and therefore corrosion can occur if the modules is subject to a salt water environment with contact to a rack of another type of metal (Electrolysis Corrosion). If required, PVC or stainless steel washers can be placed between the module frame and support structure to prevent this type of corrosion. Module support structures that are to be used to support modules at correct tilt angles should be wind and snow load rated for use by the appropriate local and civil codes prior to installation.

Sunergy modules can be mounted as following method:

Using corrosion-proof screws (M8) on the existing installing holes in the module frame.

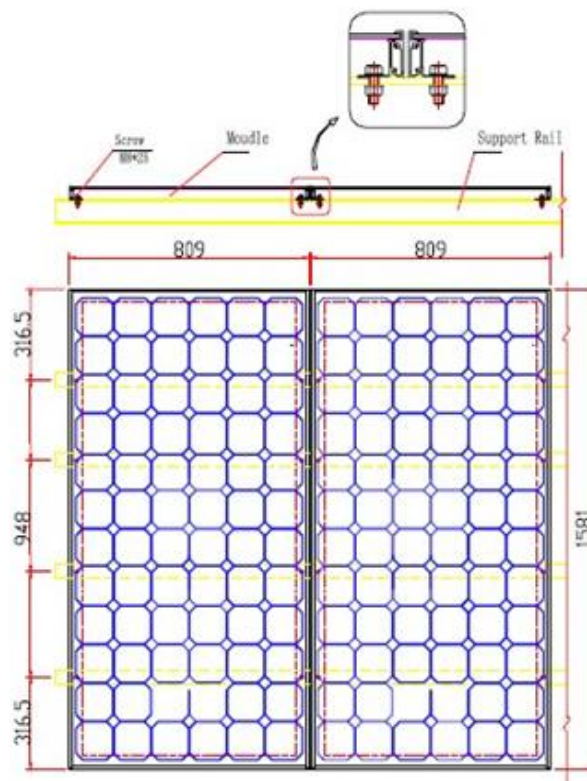

Mounting Drawing 2 (with screws)

The frame of each module has 8 mounting holes (12mm*9mm) used to secure the modules

to supporting structure. The module frame must be attached to a supporting structure using M8 stainless steel hardware together with spring washers and flat washers in eight places symmetrical on the SUN module. The  applied torque is about 8 Newton-meters.

The module clamps must not come into contact with the front glass and must not deform the frame. Avoid shadowing effects from the module clamps and the insertion systems. It is not permitted to modify the module frame under any circumstances. Recommended distance between 2 solar modules is 5mm considering linear thermal expansion of the module frames. Clearance between the module frame and mounting surface may be required to prevent the junction box from touching the surface, and to circulate cooling air around the back of the module.

10. GROUNDING

All module frames and mounting racks must be properly grounded in accordance with the appropriate respective national electrical code. Proper grounding is achieved by connecting the module frame(s) and structural members contiguously one to another using a suitable grounding conductor. The grounding conductor or strap may be copper, copper alloy, or other material acceptable for use as an electrical conductor per respective National Electrical Codes. The grounding conductor must then make a connection to earth using a suitable earth ground electrode.

Attach a separate conductor as grounding wire to one of the 4mm diameter grounding holes marked on the module frame with a set of M4 screw, cup washer, flat washer, tooth washer, and M4 nut . This is to ensure positive electrical contact with the frame.

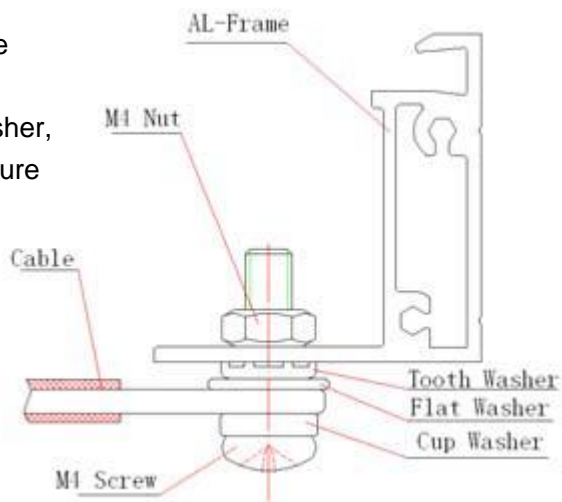

**Schematic drawing
for SPV module grounding**

11. INSTALLATION WORK

Using corrosion-proof screws (M8) on the existing installing holes in the module frame.

11.1 Secure the supporting structure according to the mounting holes in the frame of each module.

11.2 The module frame must be attached to a supporting structure using M8 stainless steel hardware together with spring washers and flat washers in eight places symmetrical on

the module.

11.3 Clearance between the module frame and mounting surface may be required to prevent the junction box from touching the surface, and to circulate cooling air around the back of the module.

11.4 Connecting the solar panels.

12. Connect each array according to the solar array connection examples.

12.1 There is a cable (+) and a cable (-) on the rear side of each solar panel. Connect the waterproof connectors on these cables, making sure to push the connectors all the way in.

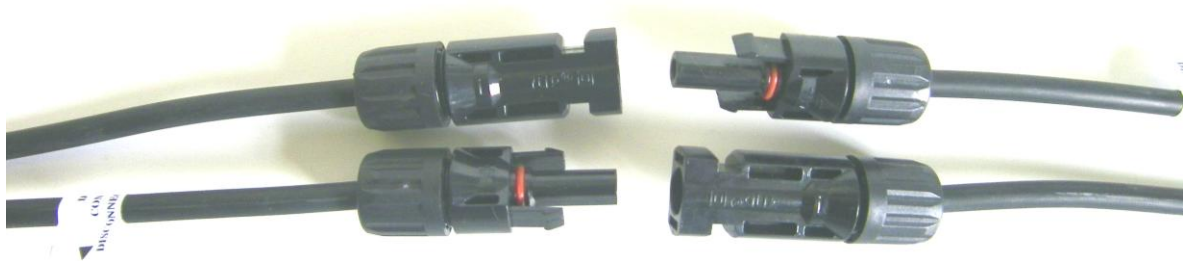

12.2 On the first solar panel, connect the positive home run cable to the positive array output cable, and connect the negative cable to the positive cable of the second solar panel. On the second solar panel, connect the negative cable to the positive cable of the third solar panel. Continue until you have series connected the appropriate number of panels for the desired voltage.

12.3 When you have made direct connections between the specified number of solar panels, use a digital multimeter to measure the voltage and current output of the array.

12.4 Organize the cables between solar panels.

13. Daily maintenance instructions

13.1 Do not clean the modules without professional authorized, and ensure the appropriate facilities to conduct security operations and aerial work with high-altitude awareness of the danger.

13.2 Checking the glass for cracks and damage before cleaning the module. If the modules have been broken, do not be cleaned, and immediately inform the installer or maintainer.

13.3 Do not use cleaning components of a strong type of chemical or abrasive detergent and disinfectant operations. To prevent serious pollution will reduce the output power. We recommend using water to clean modules. If the animals that produce the dirt, a mild soapy water and neutral disinfectant will be recommended. If necessary use a soft sponge or cloth to wipe the modules, do not force or scratch the modules hard. Do not wear jewelry or watches during cleaning the modules, Do not scraped off the dirt of animal from the components hard. Over scratches cause power attenuation, and void your warranty policy. When the module of the tilt angle is more than 15 degrees, the modules can self clean naturally; when the component's

angle less than 15 degrees, regular cleaning is necessary. Regular inspection mounting bracket corrosion or not, if we find evidence of corrosion, please consult installers; Regularly check the integrity of the ground terminal, but do not try to change the electrical connection, if you suspect a loose connection, please contact the installer.

13.4 If you have any question, consult a qualified installer or maintainer for the help.

Date sheet for module types of the family

Parameters	SUN235-60M	SUN240-60M	SUN245-60M	SUN250-60M	SUN255-60M	SUN260-60M	SUN265-60M	SUN270-60M	SUN275-60M	SUN280-60M
STC open-circuit voltage (with tolerance), [V]:	35.80±5%	36.20±5%	36.80±5%	37.30 ±5%	37.40 ±5%	38.00±5%	38.10±5%	38.20±5%	38.30±5%	38.32±5%
STC short-circuit current (with tolerance), [A]:	8.54±5%	8.63±5%	8.65±5%	8.74±5%	8.85±5%	8.89±5%	9.02±5%	9.07±5%	9.21±5%	9.35±5%
STC voltage at max. power: (with tolerance) [V]:	29.30±5%	29.60±5%	30.10±5%	30.50±5%	30.60±5%	31.10±5%	31.30±5%	31.70±5%	31.90±5%	32.10±5%
STC current at max. power (with tolerance), [A]:	8.03±5%	8.11±5%	8.13±5%	8.21±5%	8.32±5%	8.35±5%	8.48±5%	8.51±5%	8.63±5%	8.72±5%
STC nominal max. power (with tolerance), [W]:	235.00±5%	240.00 ±5%	245.00 ±5%	250.00 ±5%	255.00 ±5%	260.00 ±5%	265.00 ±5%	270.00 ±5%	275.00 ±5%	280.00 ±5%
Dimensions(L*W*H)	1640 x 990 x 40 [mm] & 1640 x 990 x 45 [mm] & 1640 x 990 x 50 [mm]]& 1640 x 990 x 35 [mm]									
Weigh(kg)	21.0kg (with 3.2mm glass), 24.2 kg (with 4.0mm glass)&21.5 kg (with 3.2mm glass), 24.7kg (with 4.0mm glass)&22.0 kg (with 3.2mm glass), 25.2kg (with 4.0mm glass)									
Mono crystalline silicon solar cell	156*156mm									

Parameters	SUN285-72M	SUN290-72M	SUN295-72M	SUN300-72M	SUN305-72M	SUN310-72M	SUN315-72M	SUN320-72M	SUN325-72M	SUN330-72M
------------	------------	------------	------------	------------	------------	------------	------------	------------	------------	------------

STC open-circuit voltage (with tolerance), [V]:	43.40 ± 5%	43.80± 5%	44.40± 5%	44.60± 5%	45.10± 5%	45.40± 5%	45.90± 5%	44.90± 5%	45.10± 5%	45.50± 5%
STC short-circuit current (with tolerance), [A]:	8.54± 5%	8.63± 5%	8.65± 5%	8.74± 5%	8.79± 5%	8.89± 5%	8.95± 5%	9.04± 5%	9.14± 5%	9.24± 5%
STC voltage at max. power: (with tolerance) [V]:	35.50± 5%	35.80± 5%	36.30± 5%	36.50± 5%	36.90± 5%	37.10± 5%	37.50± 5%	37.70± 5%	37.90± 5%	38.10± 5%
STC current at max. power (with tolerance), [A]:	8.03± 5%	8.11± 5%	8.13± 5%	8.21± 5%	8.26± 5%	8.35± 5%	8.41± 5%	8.48± 5%	8.58± 5%	8.66± 5%
STC nominal max. power (with tolerance), [W]:	285.00 ± 5%	290.00 ± 5%	295.00 ± 5%	300.00 ± 5%	305.00 ± 5%	310.00 ± 5%	315.00 ± 5%	320.00 ± 5%	325.00 ± 5%	330.00 ± 5%
Dimensions(L*W*H)	1950 x 990 x 45 [mm] & 1950 x 990 x 50 [mm] & 1950 x 990 x 40 [mm]									
Weigh(kg)	24.0 kg (with 3.2mm glass), 27.8 kg (with 4.0mm glass)&25.0 kg (with 3.2mm glass), 28.8 kg (with 4.0mm glass)									
Mono crystalline silicon solar cell	156*156mm									

Parameters	SUN205-60P	SUN210-60P	SUN215-60P	SUN220-60P	SUN225-60P	SUN230-60P	SUN235-60P	SUN240-60P	SUN245-60P	SUN250-60P
STC open-circuit voltage (with tolerance), [V]:	35.80 ± 5%	35.80 ± 5%	36.20 ± 5%	36.20 ± 5%	36.20 ± 5%	36.20 ± 5%	35.60 ± 5%	35.70 ± 5%	36.10 ± 5%	36.30 ± 5%
STC short-circuit current (with tolerance), [A]:	7.97 ± 5%	8.02 ± 5%	8.08 ± 5%	8.32 ± 5%	8.42 ± 5%	8.60 ± 5%	8.43 ± 5%	8.57 ± 5%	8.63 ± 5%	8.71 ± 5%
STC voltage at max. power: (with tolerance) [V]:	28.80 ± 5%	28.80 ± 5%	28.80 ± 5%	29.10 ± 5%	29.10 ± 5%	29.10 ± 5%	29.80 ± 5%	30.00 ± 5%	30.40 ± 5%	30.60 ± 5%
STC current at max. power (with tolerance), [A]:	7.12 ± 5%	7.29 ± 5%	7.47 ± 5%	7.56 ± 5%	7.73 ± 5%	7.90 ± 5%	7.88 ± 5%	8.00 ± 5%	8.05 ± 5%	8.17 ± 5%
STC nominal max. power (with tolerance), [W]:	205.00 ± 5%	210.00 ± 5%	215.00 ± 5%	220.00 ± 5%	225.00 ± 5%	230.00 ± 5%	235.00 ± 5%	240.00 ± 5%	245.00 ± 5%	250.00 ± 5%
Dimensions(L*W*H)	1640x990x45(mm) & 1640x990x50 (mm) & 1640x990x40 (mm) & 1640x990x35 (mm)									
Weigh(kg)	16.8kg(with 3.2mm glass), 18.9kg(with 4.0mm glass)(approx)									
Poly crystalline silicon solar cell	156*156mm									
Parameters	SUN255-60P	SUN260-60P	SUN265-60P	SUN270-60P	SUN275-60P					
STC open-circuit voltage (with tolerance), [V]:	36.40 ± 5%	36.70 ± 5%	37.00 ± 5%	37.20 ± 5%	37.3 ± 5%					
STC short-circuit current (with tolerance), [A]:	8.80 ± 5%	8.89 ± 5%	8.94 ± 5%	9.06 ± 5%	9.20 ± 5%					
STC voltage at max. power: (with tolerance) [V]:	30.70 ± 5%	30.90 ± 5%	31.00 ± 5%	31.20 ± 5%	31.30 ± 5%					
STC current at max. power (with tolerance), [A]:	8.30 ± 5%	8.42 ± 5%	8.54 ± 5%	8.65 ± 5%	8.78 ± 5%					

tolerance), [A]:	5%	5%	5%	5%	5%					
STC nominal max. power (with tolerance), [W]:	255.00 ± 5%	260.00 ± 5%	265.00 ± 5%	270.00 ± 5%	275.00 ± 5%					
Dimensions(L*W*H)	1640x990x45(mm) &1640x990x50 (mm) &1640x990x40 (mm) &1640x990x35 (mm)									
Weigh(kg)	16.8kg(with 3.2mm glass),18.9kg(with 4.0mm glass)(approx)									
Poly crystalline silicon solar cell	156*156mm									

Parameters	SUN230-72P	SUN240-72P	SUN250-72P	SUN255-72P	SUN260-72P	SUN265-72P	SUN270-72P	SUN280-72P	SUN285-72P	SUN290-72P
STC open-circuit voltage (with tolerance), [V]:	42.20 ± 5%	42.20 ± 5%	43.00 ± 5%	43.00 ± 5%	43.20 ± 5%	43.40 ± 5%	43.40 ± 5%	44.00 ± 5%	42.70 ± 5%	43.20 ± 5%
STC short-circuit current (with tolerance), [A]:	7.54 ± 5%	7.70 ± 5%	7.94 ± 5%	8.10 ± 5%	8.22 ± 5%	8.32 ± 5%	8.48 ± 5%	8.58 ± 5%	8.51 ± 5%	8.57 ± 5%
STC voltage at max. power: (with tolerance) [V]:	34.20 ± 5%	34.40 ± 5%	34.60 ± 5%	34.60 ± 5%	34.80 ± 5%	35.00 ± 5%	35.00 ± 5%	35.50 ± 5%	35.90 ± 5%	36.30 ± 5%
STC current at max. power (with tolerance), [A]:	6.73 ± 5%	6.98 ± 5%	7.25 ± 5%	7.37 ± 5%	7.48 ± 5%	7.58 ± 5%	7.70 ± 5%	7.89 ± 5%	7.94 ± 5%	8.00 ± 5%
STC nominal max. power (with tolerance), [W]:	230.00 ± 5%	240.00 ± 5%	250.00 ± 5%	255.00 ± 5%	260.00 ± 5%	265.00 ± 5%	270.00 ± 5%	280.00 ± 5%	285.00 ± 5%	290.00 ± 5%

Dimensions(L*W*H)	1950x990x45(mm)									
Weigh(kg)	23.0kg(with 3.2mm glass),25.5kg(with 4.0mm glass)(approx)									
Poly crystalline silicon solar cell	156*156mm									

Parameters	SUN295-72P	SUN300-72P	SUN305-72P	SUN310-72P	SUN315-72P	SUN320-72P	SUN325-72P			
STC open-circuit voltage (with tolerance), [V]:	43.30 ± 5%	43.60 ± 5%	43.70 ± 5%	44.00 ± 5%	44.30 ± 5%	44.60 ± 5%	44.90 ± 5%			
STC short-circuit current (with tolerance), [A]:	8.64 ± 5%	8.71 ± 5%	8.78 ± 5%	8.86 ± 5%	8.93 ± 5%	9.03 ± 5%	9.10 ± 5%			
STC voltage at max. power: (with tolerance) [V]:	36.50 ± 5%	36.70 ± 5%	36.90 ± 5%	37.10 ± 5%	37.30 ± 5%	37.50 ± 5%	37.70 ± 5%			
STC current at max. power (with tolerance), [A]:	8.08 ± 5%	8.17 ± 5%	8.27 ± 5%	8.36 ± 5%	8.44 ± 5%	8.53 ± 5%	8.62 ± 5%			
STC nominal max. power (with tolerance), [W]:	295.00 ± 5%	300.00 ± 5%	305.00 ± 5%	310.00 ± 5%	315.00 ± 5%	320.00 ± 5%	325.00 ± 5%			

Dimensions(L*W*H)	1950x990x45(mm) &1950x990x50(mm) &1950x990x40(mm)									
Weigh(kg)	23.0kg(with 3.2mm glass),25.5kg(with 4.0mm glass)(approx)									
Poly crystalline silicon solar cell	156*156mm									